

Hx22 Series



SPECIFICATIONS

Sensor Power	Induced from monitored conductor
Insulation Class	600VAC RMS (UL), 300VAC RMS (CE)
Frequency	50/60 Hz nominal
Temperature Range	-15° to 60°C (5° to 140°F)
Humidity Range	10-90% RH non-condensing
Accuracy	±2% F.S. from 10% to 100% (selected range)
Response Time	2 sec.
Terminal Block Wire Size	24-14 AWG (0.2 to 2.1 mm ²)
Terminal Block Torque	3.5 to 4.4 in-lbs (0.4 to 0.5 N-m)
Agency Approvals	UL 508 open device listing; CE: EN61010-1, CAT III, pollution degree 2, basic insulation

EXAMPLE LINEAR OUTPUT

Scale software as shown

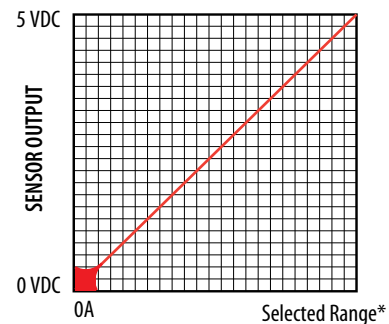

SENSED AMPS

*Factory calibrated ranges selected with the amperage range switch

Load Trending With 0-5 VDC Output

FEATURES

- Self-powered analog current sensor simplifies installation
- No external power required for sensor...no extra power supplies needed
- Self-gripping, split-core design for fast retrofit installation...no need to remove conductor (H922)
- Economical solid-core models feature adjustable bracket for easy alignment (H722xC)
- No jumpers on unit...reduces installation error
- Selectable factory calibrated ranges for increased flexibility and resolution
- Some models available with three field-selectable ranges per unit...fewer versions to choose from, stock, and install
- Mini-sized H822 fits easily in tight enclosures
- Removable bracket on H922 can be installed in three different configurations...added flexibility
- 100% solid state, no moving parts to fail
- Fixed current models...speed installation
- 5-year warranty

DESCRIPTION

The **Hawkeye 722, 822, and 922** provide accurate load trending information with a proportional 0-5VDC output signal. Slide-switches provide easy field selection of monitored amperage range without jumpers (available on some models).

APPLICATIONS

- Load trending
- Motor control
- Positive proof of flow

Monitoring Fan /Pump Motors for Positive Proof of Flow

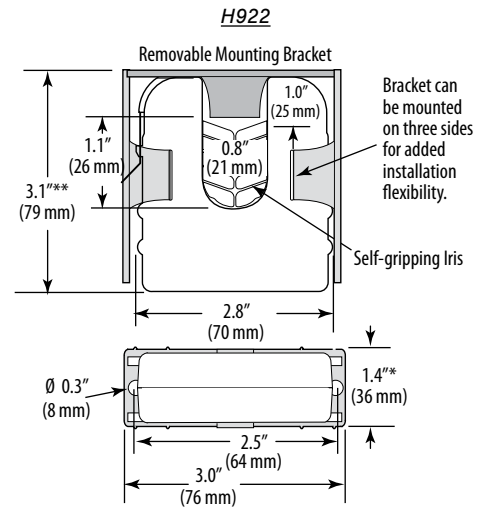
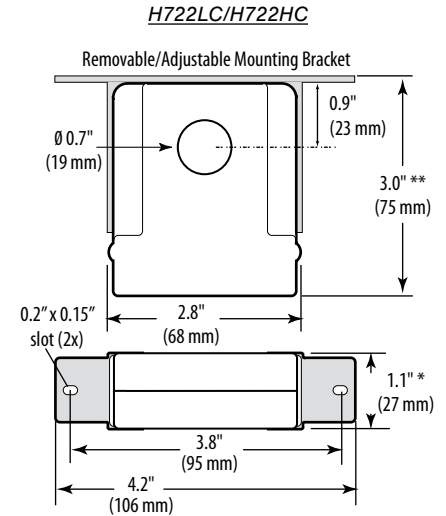
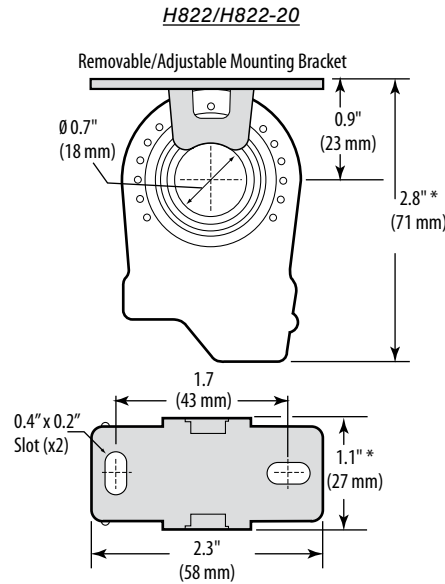
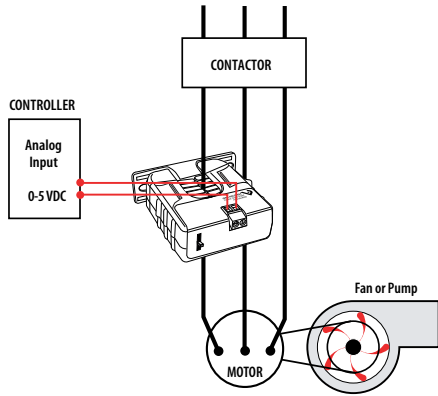

* Terminal block may extend up to 1/8" over the height dimensions shown.
 ** Slide switch may extend up to 1/4" over the height dimensions shown.

ORDERING INFORMATION



MODEL	AMPERAGE RANGE	SENSOR OUTPUT	HOUSING	UL	CE	RoHS
H722LC	0 - 10/20/40A	0 - 5VDC	Solid-Core	●	●	
H722HC	0 - 50/100/200A		Solid-Core	●	●	
H822	0 - 10A		Solid-Core	●		●
H822-20	0 - 20A		Solid-Core	●		●
H922	0 - 30/60/120A		Split-Core	● ¹	●	
H922030A	0 - 30A		Split-Core		●	
H922060A	0 - 60A		Split-Core		●	
H922120A	0 - 120A		Split-Core		●	

1 Listed for use on 75°C insulated conductors.

ACCESSORIES

DIN Rail Clip Set (AH01)
 DIN Rail (AV01) and DIN Stop Clip (AV02)



isweek www.isweek.cn

公司名: 深圳市工采网络科技有限公司

电话: +86-755-83289036

地址: 广东省深圳市南山区高新南一道中国科技开发院3号楼16层

传真: +86-755-83289052

邮箱: sales@isweek.cn