

A7810 Acquilite™ & A8810 Acquisuite™



A8810

A7810

Flexible Data Server for Embedded Applications

FEATURES

- Tracks data in real time...providing the right information for trending, planning, and identifying waste
- Alarm notification for data points above or below target levels... quick notification for optimal performance maintenance
- Compatible with multiple communication protocols...push or pull data to energy dashboards and software applications for easy system integration
- Industrial temperature range (-30° to 70°C), perfect for embedded applications...speeds up development & integration of energy data
- DIN rail mounting...easy installation

DESCRIPTION

The **A7810 Acquilite™** and **A8810 Acquisuite™** data acquisition server for embedded applications allows users to collect energy data from meters and environmental sensors and send it via Modbus communication protocol (wired or wireless using the H8830) to IP-based applications. No software is required. Operation is plug-and-play, and information can be accessed using any web browser. The A7810 supports four pulse inputs, while the A8810 supports Modbus serial input.

The compact housing and industrial temperature range make the A7810 & A8810 ideal for embedded applications. Reduce development time and speed up integration by collecting and distributing energy data directly from your equipment.

SPECIFICATIONS

Input Power	24VDC, 500mA*
Isolation	
A7810	RJ45 Ethernet isolated to 1500VDC from main board (power and pulse inputs not isolated)
A8810	RJ45 Ethernet and RS-485 port isolated to 1500VDC from main board (power and USB not isolated)
Main Processor	ARM 9 embedded CPU
Operating System	Linux 2.6
Flash ROM	16 MB NOR Flash
Memory	32 MB RAM
LEDs	
A7810	Ethernet, pulse (x4), power, alarm
A8810	Ethernet, Modbus TX/RX, power, alarm
Console	2 x 16 LCD character, two push buttons
Interval Recording	1 to 60 minutes, user selectable (default 15 minutes)
Pulse Inputs	
A7810	4 inputs, dry contact, standard or KYZ, closure threshold 100Ω to 2.5kΩ user selectable; max. rate 10 Hz; min. width 50 msec
Serial Port Input	
A8810	RS-485 Modbus, supports up to 32 external devices (expandable)
Agency Approvals	
A7810	FCC CFR 47 Part 15, Class A; EN 61000; EN 61326; UL61010 recognized; EN 61010
A8810	CE; FCC Part 15, Class A; EN 61000; EN 61326; UL61010 recognized
COMMUNICATION	
Protocols	
A7810	Modbus/TCP, TCP/IP, PPP, HTTP/HTML, FTP, NTP, XML, SNMP-Trap
A8810	Modbus/RTU, Modbus/TCP, TCP/IP, PPP, HTTP/HTML, FTP, NTP, XML, SNMP-Trap
LAN	RJ45 10/100 Ethernet, auto polarity
ENVIRONMENTAL	
Operating Temp Range	-30° to 70°C (-22° to 158°F)
Operating Humidity Range	0-95% RH noncondensing; indoor use only

*This unit is to be sourced by a Class 2 power supply with the following output: 24VDC, 500mA min. not to exceed 8A.

APPLICATIONS

- Measurement and verification (M&V)
- Reduce energy costs
- Access energy information from local and remote sites
- Benchmark building energy usage
- Demand response
- Renewable energy

APPLICATION EXAMPLES

DIMENSIONAL DRAWING

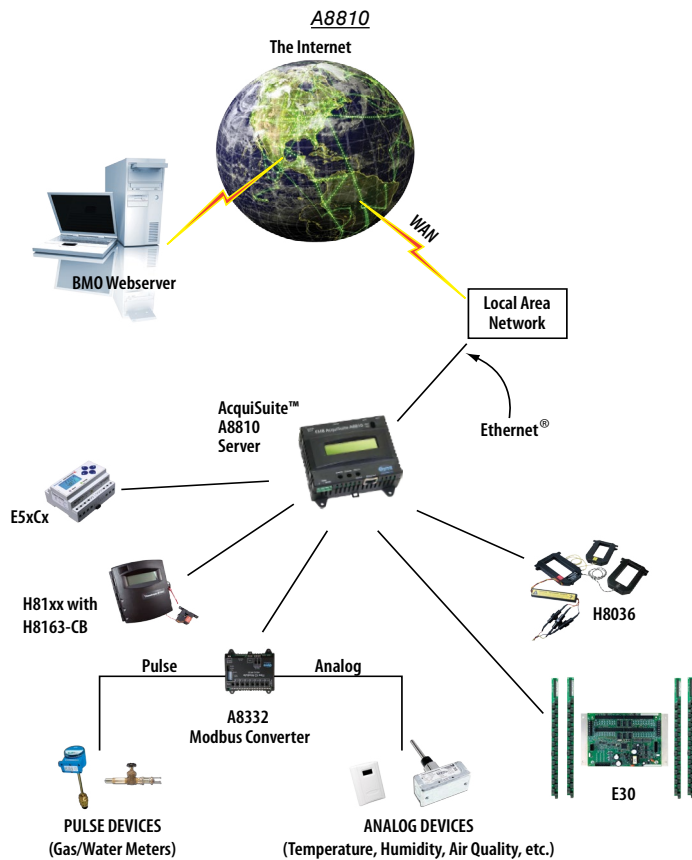
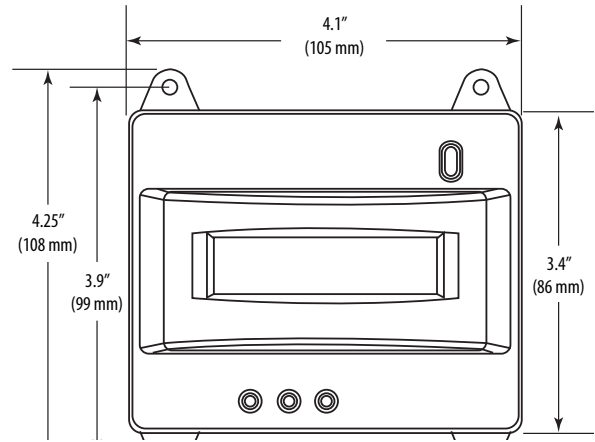
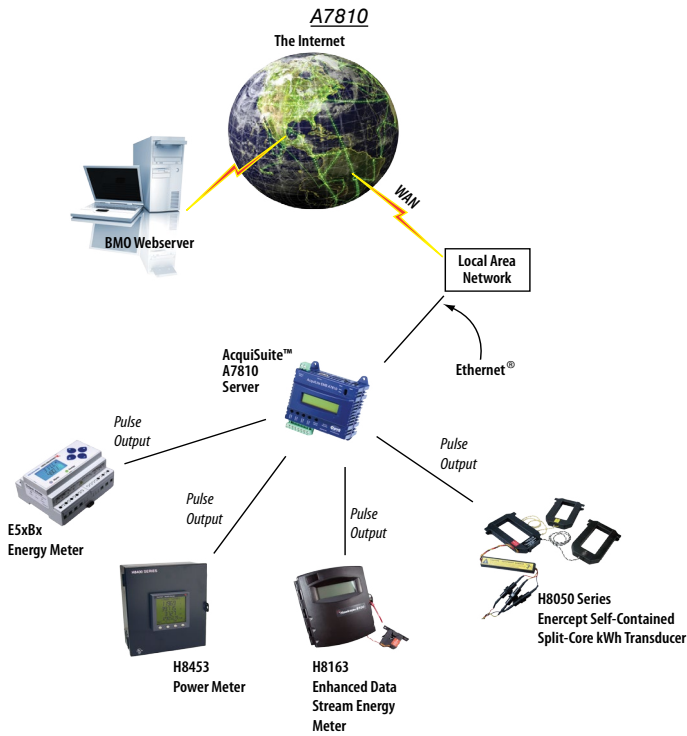

THE ACQUISITE SYSTEM ALLOWS...	
...Internet Display of Data Using the BMO Website	View performance data in an easy graphical format. Store, display, and download historical data in a secure SQL database. Design custom views of data from one or more buildings or systems.
...Security and Flexibility	Store data on board in nonvolatile memory. Protect information in the event of a power failure. Time-stamp all interval data with an on-board real-time clock.
...Compatibility with Existing Systems	Use the I/O module to connect to existing sensors and meters. Use TCP/IP protocols to interface with spreadsheets, databases, text files, etc. (A8810 only)

ORDERING INFORMATION



MODEL	DESCRIPTION
A7810	AcquiLite EMB data acquisition server, pulse input
A8810	AcquiSuite EMB data acquisition server, Modbus serial input